

Powering Telephony on Coax Networks - A Guide to Dimensioning

Tim Robbins and John Hawkins

Telstra Research Laboratories
Box 249 Rosebank MDC, Clayton,
Victoria 3168, AUSTRALIA

Email: t.robbins@trl.telstra.com.au

Abstract - This paper describes a methodology for use in dimensioning the power requirements for provision of telephony over coaxial cable networks. A model describing the distributed power system elements in a coax network is presented. Guidelines are given for cost optimisation of the coax power network. An example of dimensioning the power for telephony on a typical coax network for a given grade-of-service is also presented.

1. Introduction

The convergence of telecommunications, computing, and entertainment may demand the integration of traditional telephony services into broadband carriage. Many telecommunications companies and cable TV operators are now assessing either the introduction or upgrading of coaxial cable networks for the provision of telephony and other services.

Power consumption for POTS has always been traffic dependent. With traditional central office-based telephony, only a relatively small component of the exchange power consumption is traffic dependent. However, in the many new access network architectures, such as hybrid fibre coax (HFC) and fibre to the curb (FTTC), line termination equipment will have significant traffic dependent power consumption. These new networks also serve smaller customer groups and therefore they typically involve a localised power distribution architecture. The relationship between power consumption and teletraffic is therefore different from that of the traditional exchange-based telephony infrastructure. Techniques to analyse the traffic dependency of powering typical broadband systems distributed throughout a coax customer access network have recently been reported [1,2].

The power load placed on a coax network will increase with the introduction of telephony network interface units (NIUs). The NIU will have a teletraffic power dependency. Furthermore, an expectation of high availability POTS implies a need for acceptable back-up

time for the network to alleviate service unavailability due to long duration AC mains outages. The life-cycle costs of battery backed powering in these small customer areas is now seen as a significant portion of both the initial capital and operational cost of a telephony service.

For telephony, an important aspect is how to cost-effectively provide a power system to meet the customers' perspective of telephony as a highly available telecommunications service. To be cost-effective, accurate dimensioning of the power system is an important requirement. Dimensioning, that is determining the load, for a coax network power system is a complex process, as traffic dependent loads are placed along a branch-tree structure that is unique for each serving area. Over-dimensioning represents unnecessary life-cycle costs which may be difficult to justify in a competitive environment. Under-dimensioning may result in service loss due to powering and thus contribute to service unavailability.

This paper describes the use of power system element models and simulation techniques to develop guidelines for the cost-effective design of a coax network power system delivering telephony. A key part of the modelling is the inclusion of the traffic dependent *powering* grade-of-service (GoS) specification and its effect on the power consumption of telephony NIUs. Dimensioning guidelines are discussed in terms of cost-optimised balance between service demand and GoS levels.

2. The Coax Network Power System

Coax cable and HFC networks can be characterised as a distribution of active electronic elements throughout the customer access network. This distribution of equipment can be visualised as a signal transmission (rf) network overlaid with a powering network. Powering elements may not necessarily be co-located with the transmission elements. The impact of teletraffic variations on powering telephony services will therefore

depend on the signal and power network architectures. For telephony, only the network elements which influence the powering need be considered. *Figure 1* shows a schematic representation of a complex branch-tree structure which might be seen as generic in representing a typical coax network. It is important to note that *Figure 1* does not necessarily portray the full signal transmission network.

As shown in *Figure 1*, the power supply is connected to the coax network via a line power interface element. Network elements that consume power are the amplifiers and the network interface units (NIUs). Power losses from splitters and couplers are negligible, and are therefore not considered. Coax segments connect the network elements and introduce a small but significant parasitic resistance component. Amplifiers may have single or multiple outputs legs, and the hub amplifier will have an optical input. The network may use NIUs with just one or a variety of customer serving sizes. *Figure 1* illustrates a network using NIUs with 4 and 10 line serving sizes.

3. Factors Affecting Power Element Modelling

The power dimensioning task requires some approach to determine or model the load for the network architecture. The load is, of course, complicated, since voltage line drops will vary with both the length of the coax segment and the current demand in the segment. The power demand will be dictated by the number of

NIUs connected to a segment, and the number of segments will depend on the topology of the branch-tree structure, which in turn, depends on the geography of the residential customer serving area. However, progress with this seemingly daunting task can be made with knowledge about the operating characteristics of some of the network elements.

NIU power consumption

A telephony NIU has a complex load characteristic that is traffic dependent. Both the dependence of NIU power on traffic and teletraffic modelling have been comprehensively described [1,2]. Each NIU exhibits a time-variable load characteristic, with the power consumed by the NIU depending on the state of use of the connected customer telephony equipment (ie. ring, off-hook and on-hook). If there is insufficient power available for the customer's NIU, service failure will result. The rate of failure due to inadequate powering is called powering GoS. The numeric level of powering GoS indicates the amount of time the service is unavailable (ie. a higher powering GoS level delivers a higher telephony service unavailability). The peak NIU power required to achieve a given level of powering GoS for given traffic conditions can be modelled [1]. In *Figure 2* and *Figure 3*, the peak power load for a NIU serving 4 and 10 telephony lines respectively is plotted as a function of powering GoS for different teletraffic rates (Erlang). For power system dimensioning, this peak power consumed by an individual NIU can be represented by a constant power load.

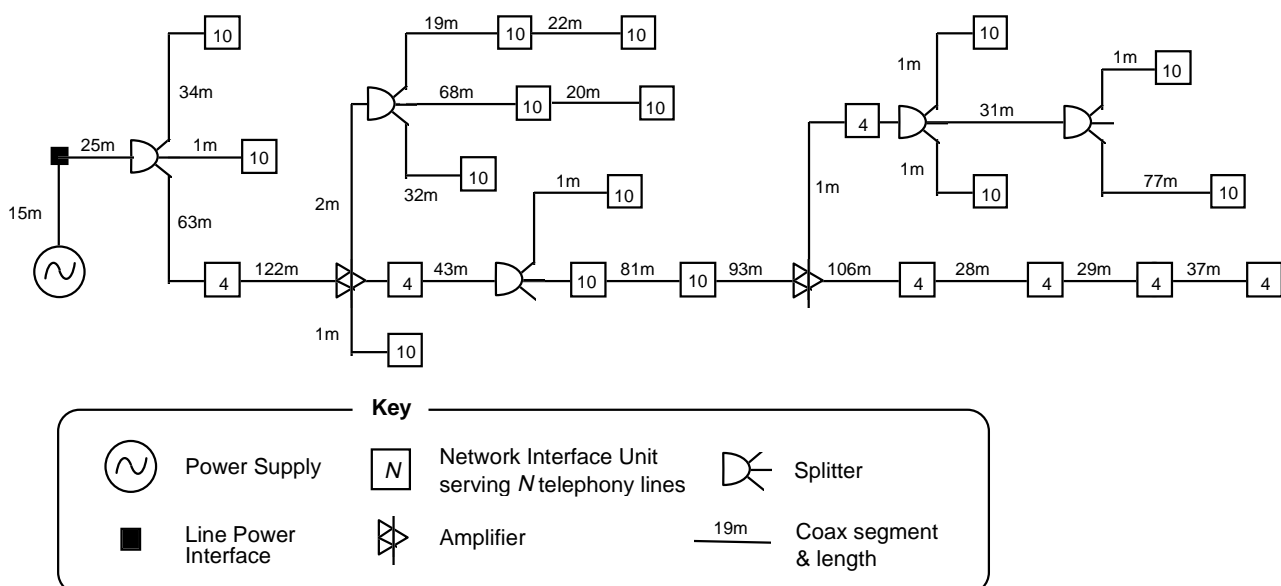

Figure 1 Representative schematic of power-related elements in a typical coax network

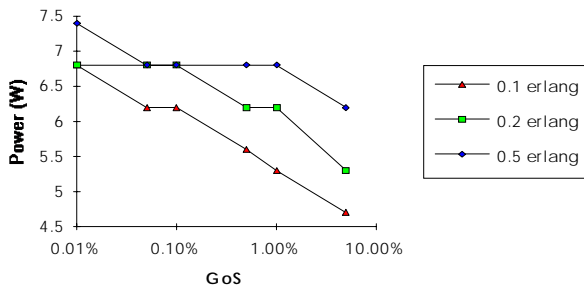

Figure 2 Typical NIU power consumption for 4 connected telephony lines

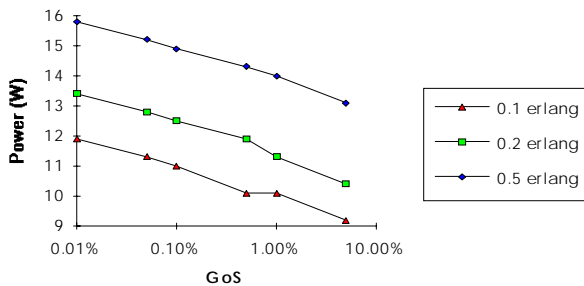

Figure 3 Typical NIU power consumption for 10 connected telephony lines

The important information in these figures is three fold. First, an increase in the number of telephone lines connected to a NIU increases the power consumption, but the increase is not linear. Second, there is considerable power saving by sustaining a higher level of powering GoS. Third, the NIU power consumption is quite sensitive to total traffic variation.

High powering GoS is usually a result of low voltage levels at the coax network extremities which cause NIU failure under excessive traffic conditions. Powering GoS can be mitigated by the introduction of call blocking. Call blocking reduces the telephony traffic, thereby reducing NIU loading. Call blocking functionality that provides a similar powering GoS to all customers in a hub is preferable to the situation where customers located at network extremities are experiencing significant call blocking, and hence relatively high powering GoS.

Maximum current sourced from the supply

A maximum current level constraint will exist for the coax network power supply. This constraint typically causes a drooping voltage regulation characteristic on the output of the supply, leading to a voltage collapse due to the constant power characteristic of the amplifier and NIU loads.

Maximum current through network elements

A maximum current level constraint will exist for amplifiers, NIUs, splitters and line power interfaces.

This constraint is due to inductor/transformer core saturation at high current levels causing distortion products within these elements.

Minimum operating voltage of network elements

A minimum voltage level constraint will exist for amplifiers and NIUs, due to the regulation range of the internal switchmode regulator. Only elements located at the extremity of the coax network will experience low voltage levels that could fall below the minimum level during periods of excessive telephony traffic on the network.

4. Power System Element Modelling

It is now possible to model elements of the coax network power system in terms that are suitable for electrical circuit simulation. In this work, the commonly used PSpice (MicroSim) simulator has been used. Power system modelling with PSpice has been previously reported [3,4]. The element models described here are specific to PSpice, and can be used to adequately model the characteristics of a typical power supply, an amplifier, a coax segment, and a NIU at a specified level of powering GoS and teletraffic conditions.

Power supply model

A typical (ferroresonant) power supply has constant voltage and maximum current limit characteristics. A constant voltage source is considered an adequate model, as the maximum current limit is unlikely to be experienced in practice. Modelling voltage regulation with load change is complex and not recommended, as the design benefit gained is insignificant.

Amplifier model

A typical amplifier has constant power load and minimum operating voltage characteristics. A voltage-controlled current source can be used to model an amplifier, as shown schematically in Figure 4. An example of the input-voltage to output-current source transfer function is:

$$\begin{aligned}
 I_{(out)} &= P * \{ [1/LIMIT(V_{(in)}, 30, 110)] - \\
 &\quad [STP(30 - V_{(in)}) * (30 - V_{(in)}) / 900] \} \\
 &= P / V_{(in)} \quad , \text{ when } 30 < V_{(in)} < 110 \\
 &= P * V_{(in)} / 900 \quad , \text{ when } V_{(in)} < 30 \\
 &= P / 110 \quad , \text{ when } V_{(in)} > 110
 \end{aligned}$$

where, P = constant power level (watts)
 $V_{(in)}$ = source input voltage (volts)

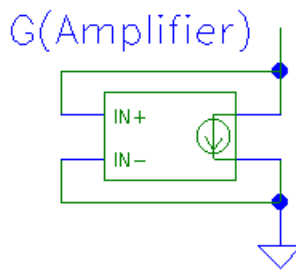

Figure 4 Amplifier Model Schematic

The LIMIT function limits $V_{(in)}$ to a minimum value of 30 and a maximum value of 110. The STP function returns a value of one if $(30 - V_{(in)}) > 0$, and a value of zero if $(30 - V_{(in)}) < 0$. Hence, this amplifier model presents a constant power load of P watts for operating voltages between 30V and 110V; a constant resistance load of $900/P$ ohms for operating voltages below 30V; and a constant current load of $P/110$ amps for operating voltages above 110V.

Coax segment model

A coax segment can be modelled as a resistance. The PSpice resistor element can be modelled by ohms per unit length, thereby accommodating length as the input parameter.

NIU model

As described in Section 3, the NIU power levels depend on the powering GoS and teletraffic conditions. For a given set of GoS and teletraffic parameters, an NIU can be modelled with constant power load and minimum operating voltage characteristics. As such, a voltage-controlled current source can be used to model an NIU, as shown schematically in Figure 5. The transfer function of the NIU model is equivalent to that presented for the amplifier model.

The constant power parameter P , is selected after consideration of the appropriate GoS and teletraffic levels and would, for instance, be selected from plots similar to those shown in Figures 2 and 3.

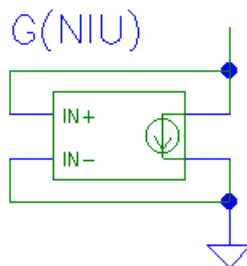

Figure 5 NIU Model Schematic

5. A Power Dimensioning Example

In order to cost-effectively design a coax network power system for telephony, the powering, service demand and powering GoS parameters must be optimally specified. As an example of the dimensioning task, the network described in Figure 1 can be analysed for worst-case end-of-line voltage. In Figure 6 the effect on end-of-line voltage caused by powering GoS is shown for different teletraffic rates. In this example, the power supply voltage used was 50V, as this level is presently used by Telstra. Also, amplifier power consumption was 47W and coax resistance was $5.6 \Omega/\text{km}$ loop. Figure 6 shows that for low powering GoS, that is low service unavailability due to power, NIU loading of the network segments *increases* and this results in lower end-of-line voltages.

Outputs like Figure 6 contain important information to guide power network design. For example, Figure 6 may indicate that an extra power supply is required in order to deliver a reasonable powering GoS under high traffic conditions. While NIU power consumption and line voltage drops will dominate power design considerations, other factors such as service demand and end-to-end GoS also need to be taken into account.

Service demand

Service demand will determine the NIU size that is appropriate to serve the number of telephony lines connected to a particular NIU. To determine service demand requires an understanding of initial service penetration and growth forecasting for these new networks.

Telephony service penetration will depend on the number of living units passed by the coax network, market competition and the need for 2nd lines. Other telecommunications services delivered over the coax network may also require powering at the NIU (eg. ISDN). The future growth/decline in telephony lines, and other services, introduces a large risk factor to the dimensioning of the power system.

End-to-end GoS specification

Powering GoS as discussed in this paper is only one contributor to the overall end-to-end GoS experienced by the customer. Other factors may also make a significant contribution to end-to-end GoS and quality of service, such as call blocking due to bandwidth concentration over the optical fibre link, network element failures, power supply outages, noise ingress and hum modulation.

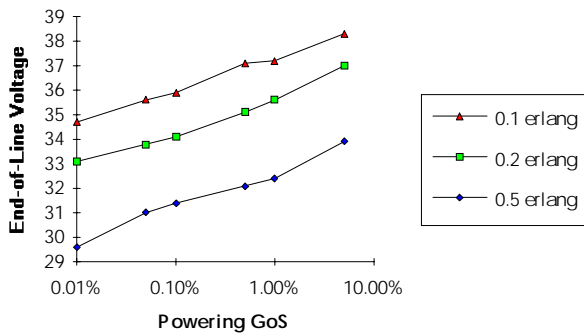

Figure 6 Simulated end-of-line voltage for example network

6. Summary for Cost-optimised Power Dimensioning

This paper has addressed power dimensioning for the delivery of telephony over a coax network. The three main design prerequisites are NIU and network electrical specifications, service demand projections and GoS specifications. Using this design information in conjunction with appropriate device models will allow an accurate analysis of the power system to be undertaken. The design can then be optimised for cost effective power supply placement in order to guarantee end-to-end GoS levels for all customers.

7. Acknowledgments

The authors would like to thank the Director of Telstra Research Laboratories for permission to publish this paper. The authors would also like to thank M.Hesse for his contributions.

8. References

- [1] M.H.Hesse & R.J.Sewell, "Powering future telephony services - a teletraffic perspective", Australian Telecommunications Research, Vol 29, No 1, 1995, pp 63-74.
- [2] M.H.Hesse & R.J.Sewell, "Powering telephony on coax networks - a teletraffic perspective", Proceedings of the Seventeenth International Telecommunications Energy Conference, The Hague, 1995, pp 207-211.
- [3] T.Robbins, "Battery model for over-current protection simulation of dc distribution systems", Proceedings of the Sixteenth International Telecommunications Energy Conference, Vancouver, 1994, pp 307-314.
- [4] T.Robbins, "Circuit-breaker model for over-current protection simulation of dc distribution systems", Proceedings of the Seventeenth International Telecommunications Energy Conference, The Hague, 1995, pp 628-631.